

**SE DESMONTA** y se recomienda realizar su colocación en la barra en el suelo, **NO** en altura.



**TAPA EXTREMA DE CIERRE**

se suministra montada

ME-1400

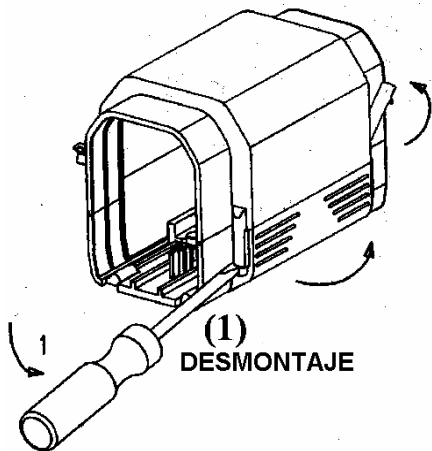

(1) DESMONTAJE

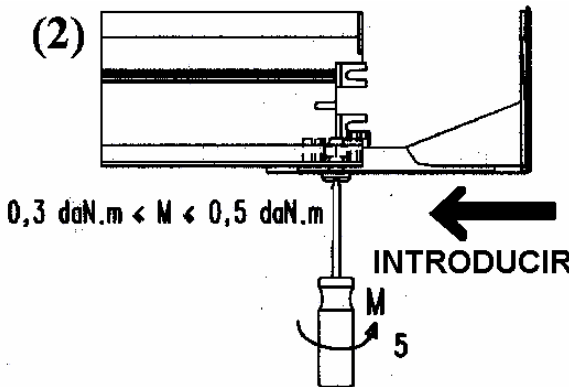

$0,3 \text{ daN.m} < M < 0,5 \text{ daN.m}$

INTRODUCIR

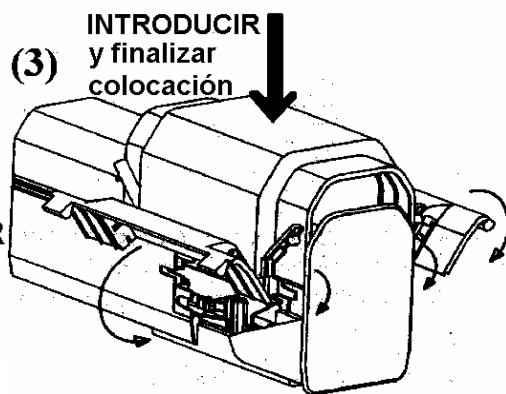

INTRODUCIR y finalizar colocación

**CAJA DE CONEXIÓN EN EXTREMO DE LÍNEA**

ME-1200

( se suministra montada )

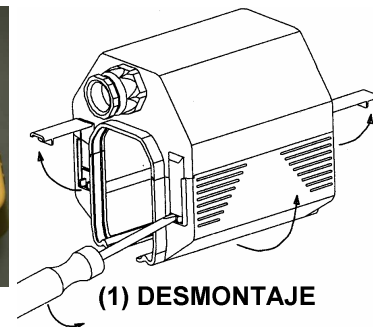
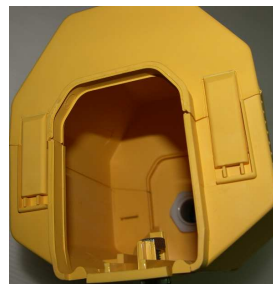

(1) DESMONTAJE

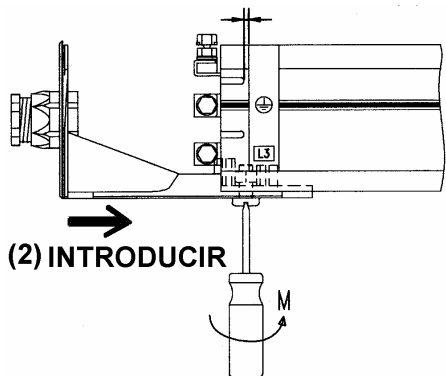

(2) INTRODUCIR

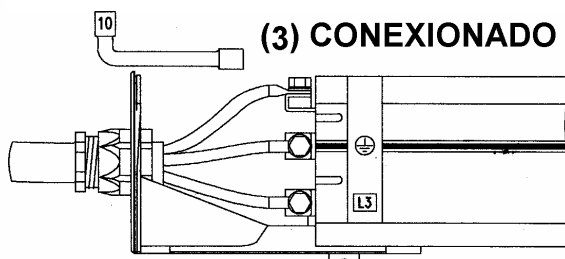

(3) CONEXIONADO

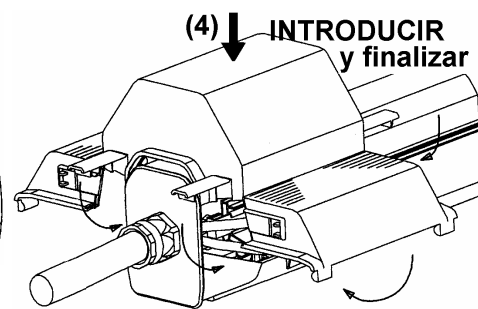

(4) INTRODUCIR y finalizar



**CARRO SIMPLE SALIDA CAJA**

40 A.  
ME - 3043

**BRAZO DE ARRASTRE**

ME - 1600

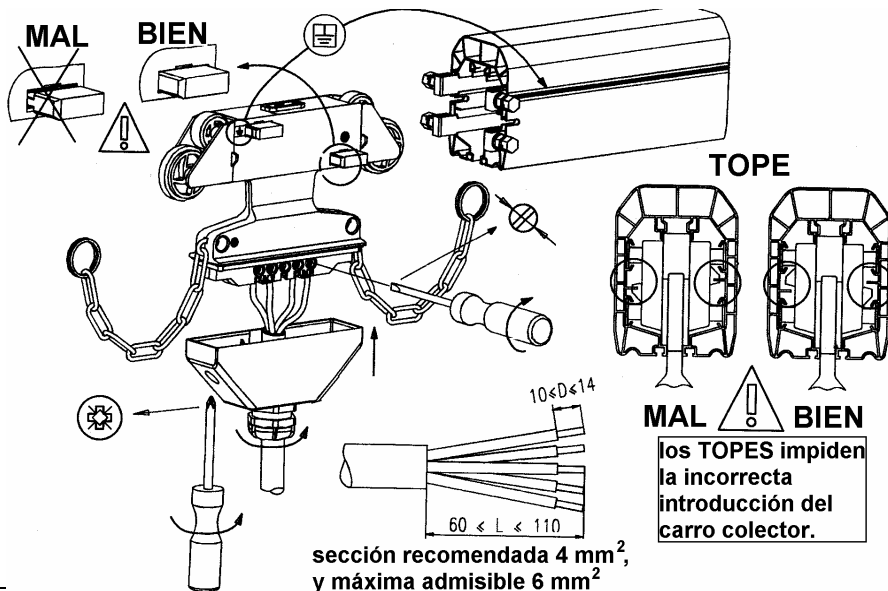

MAL

BIEN

TOPE

MAL BIEN

los TOPES impiden la incorrecta introducción del carro colector.

sección recomendada  $4 \text{ mm}^2$ , y máxima admisible  $6 \text{ mm}^2$

1



**CAMBIO DE ESCOBILLA**

2

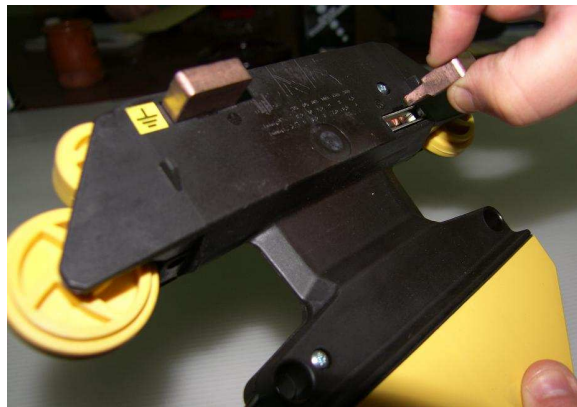

3

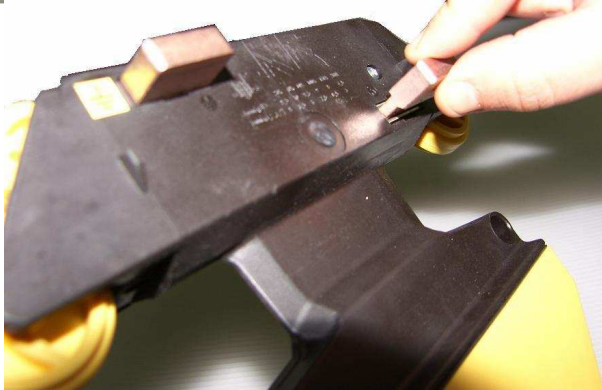

4

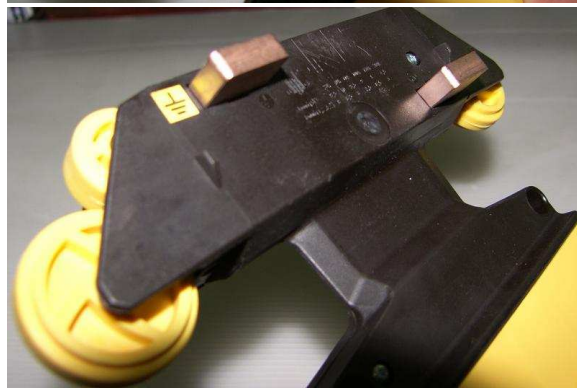

**PARA UN CORRECTO FUNCIONAMIENTO DEL CARRO COLECTOR, COLOCACIÓN DEL CABLE SALIENTE DEL CARRO Y MONTAJE DEL BRAZO DE ARRASTRE.**

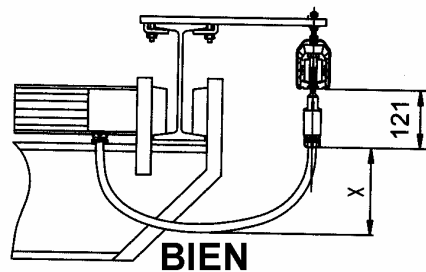
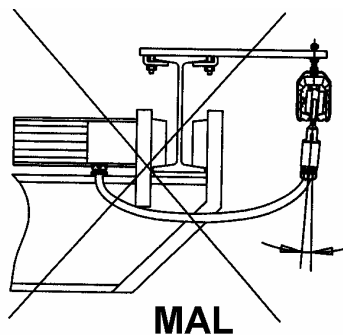

X = 40 mm. mínimo para cable H07 RNF 4G4  
 X = 100 mm. mínimo para cable H07 RNF 4G6

